



**CARLOR**  
ENGINEERING

## History

Carlor Engineering, ISO 9001 certified Belgian manufacturer, it is 15 years experience in the development of electric coolant heaters for all types of water-cooled engines. Carlor Engineering quickly became the leader in this field with the assets of a small company: reactivity, adaptation to market demand, quality and reliability.



## FLOW START

Tank-style engine pre-heating system with pump

The Flow Start is an electric coolant heater for all types of water-cooled engines. It is universal, reliable, easy-to-install and maintenance-free. The heater can be put into service a few hours before starting the engine, in order to keep the engine permanently at the required temperature. This ensures an easy full power start whatever the ambient temperature and avoids cold start mechanical damage. The system has also following advantages: fuel savings, decreasing pollution, reduced engine wear, no more difficult cold starts, vehicle cab heater instantly operational. This version is suited for all industrial applications, either stationary (generator sets) or mobile (vehicles, vans, trucks, heavy-duty vehicles)



### DELIVERED WITH FIXATION KIT.

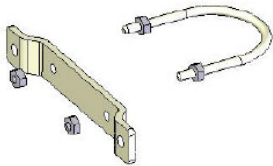

### INSTALLATION DIAGRAM

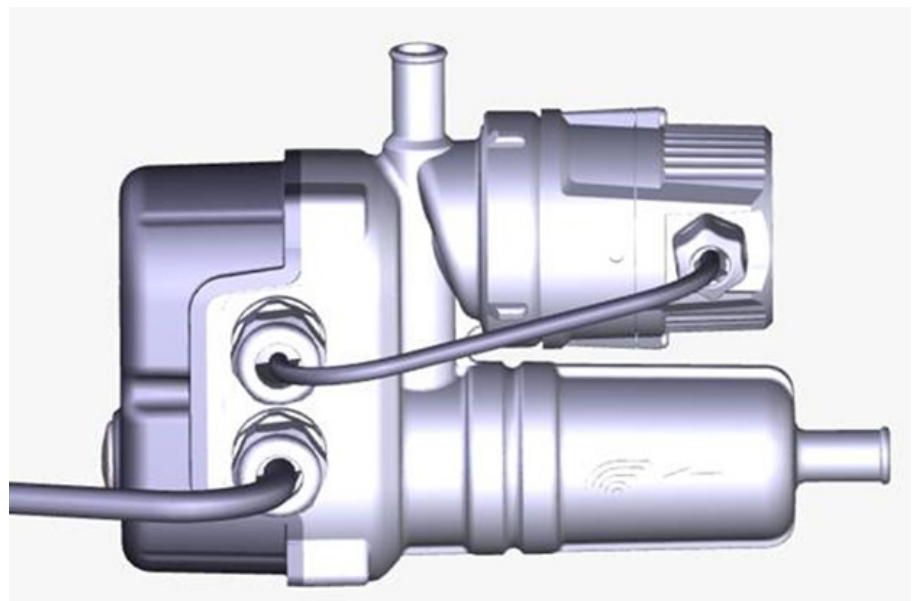
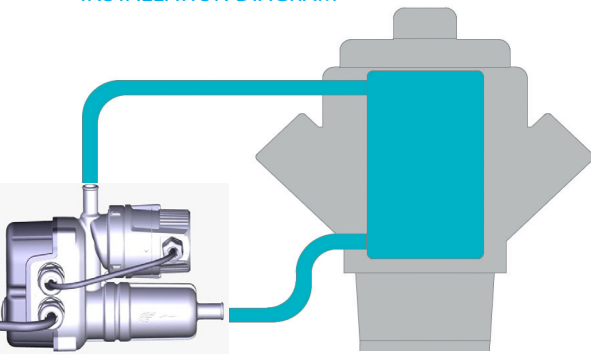

### Technical characteristics

#### PRODUCT BENEFITS

- Strong die-casted aluminium body 100% recyclable.
- Very compact product with integrated circulating pump for quick and homogeneous preheating.
- Integrated powerful circulating pump saving electricity and improving the life cycle of engine components.
- Heating element with top-quality shielding and low specific power, increasing its lifecycle and that of the coolant.
- Control thermostat with high cutout power for an optimized life cycle.
- Safety thermostat with manual re-set option to protect the heating element if water levels in the circuit are low or if the control thermostat fails.
- High waterproofness (IP67 available).
- Easy replacement of parts.
- Two years warranty on labour and spare parts.

#### HEATING UNIT

- Aluminium AS9U3 injected heating unit with impregnation treatment
- PA66 protection covers
- 200 cm (6,6 ft) power cable
- Inlet/Outlet: 5/8" (15 mm) hose barb water outlet and inlet

#### WATER TEMPERATURE CONTROL THERMOSTAT

- Fixed thermostat 34-40°C (93-104°F) or 35-50°C (95-122°F), rated 25A, 100.000 cycles.

#### CIRCULATING PUMP

- Glandless circulation pump;
- Flow rate: 300L/h @ 1m height manometer (1,3 GPM @ 1,5 PSI);
- Voltage: 120V to 230V;
- Frequency: 50 Hz and 60 Hz;
- IP67 ingress protection level available.

#### SAFETY THERMOSTAT

- Security thermostat 110 °C with manual reset, rated 25A, 6.000 cycles.

#### HEATING ELEMENT

- Low watt density heating element (7,5W / cm<sup>2</sup>, 48W / in<sup>2</sup> --> 1,5kW);
- Incoloy 800 protection sheet;
- Available powers: 500W, 1000W, 1500W, 2000W;
- Available voltages: 120V or 230V.

