

- Большой ассортимент плунжерных насосов в.д. (15 до 500 бар, от 2 до 300 л/мин.)
- Аппараты высокого давления с различными типами приводов
- Запчасти для плунжерных насосов
- Различное оборудование для автомоек (торнадоры, пеногенераторы, пистолеты и т.д.)



ТД-ГИДРОМАРКЕТ.РФ

8-800-333-52-49 (бесплатный по РФ)
+7 (499) 322-36-37 (Москва),
+7-952-784-36-96 (мобильный)

CARATTERISTICHE - SPECIFICATIONS

IN	DIAMETER	∅	1/2 BSP
	PRESS.	Min.	- 0.1 bar - 1.5 PSI
		Max.	6 bar 87 PSI
TEMP.	Max.	60° C. 140° F.	
OUT	DIAMETER	∅	3/8 BSP
SHAFT		∅	24 mm
OIL	SAE 75W 90		0.7 litri 0.18 U.S.G.
PESO WEIGHT		Kg / lbs	9.5 / 21



KIT PIEDINI cod. 07.9802.97.3 (optional)
MOUNTING RAILS KIT cod. 07.9802.97.3 (optional)
KIT SUPPORTS cod. 07.9802.97.3 (option)
JUEGO DE PIES cod. 07.9802.97.3 (opcion)

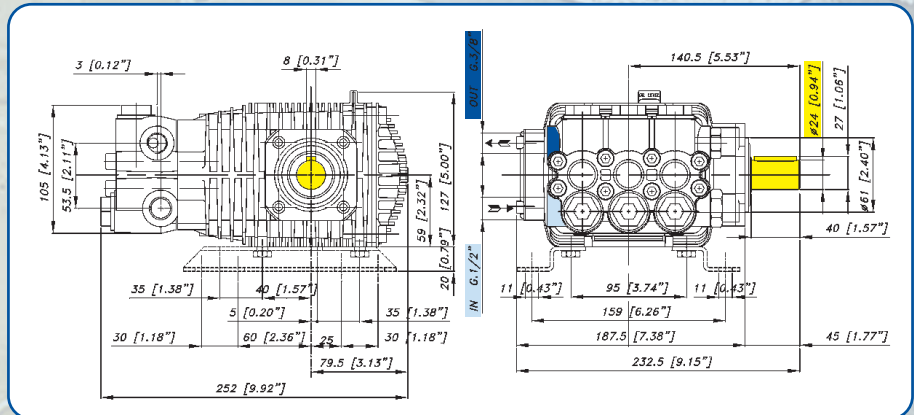

CARATTERISTICHE - FEATURES

PERFORMANCE CHART

MODELLO MODEL CODICE CODE	MAX		PRESS		RPM 950				RPM 1450				RPM 1725				PIST. PLUNG. Dia. mm	CORSA STROKE mm
	L/min	GPM	Bar	PSI	L/min	GPM	KW	HP	L/min	GPM	KW	HP	L/min	GPM	KW	HP		
TML 1220 07.2000.97.3	13.7	3.6	150	2175	7.7	2.0	2.3	3.0	12.1	3.1	3.4	4.6	13.7	3.6	4.0	5.4	18	11.2
			180	2610	7.7	2.0	2.7	3.6	12.0	3.1	4.1	5.5	13.6	3.6	4.8	6.5		
			200	2900	7.6	2.0	3.0	4.0	12.0	3.1	4.5	6.1	13.6	3.6	5.3	7.1		
TML 1320 07.2001.97.3	15.2	4.0	150	2175	8.5	2.3	2.5	3.4	13.1	3.4	3.8	5.1	15.2	4.0	4.5	6.0	18	12.4
			180	2610	8.5	2.2	3.0	4.0	13.0	3.4	4.5	6.1	15.1	4.0	5.3	7.2		
			200	2900	8.4	2.2	3.3	4.4	13.0	3.4	5.0	6.7	15.0	4.0	5.9	7.9		
TML 1520 07.2002.97.3	17.6	4.7	150	2175	9.9	2.6	2.9	3.9	15.1	4.0	4.4	5.9	17.6	4.7	5.2	7.0	18	14.4
			180	2610	9.8	2.6	3.5	4.7	15.0	4.0	5.3	7.1	17.5	4.6	6.2	8.3		
			200	2900	9.8	2.6	3.8	5.2	15.0	4.0	5.8	7.8	17.4	4.6	6.8	9.2		
TML 1720 07.2005.97.3	19.6	5.2	150	2175	11.0	2.9	3.2	4.3	17.1	4.5	4.9	6.6	19.6	5.2	5.8	7.7	18	16
			180	2610	10.9	2.9	3.9	5.2	17.0	4.5	5.8	7.8	19.5	5.1	6.9	9.2		
			200	2900	10.9	2.9	4.3	5.7	17.0	4.5	6.5	8.7	19.4	5.1	7.6	10.2		
TML 2020 07.2011.97.3	22.9	6.0	150	2175	12.8	3.4	3.8	5.1	20.1	5.2	5.7	7.7	22.9	6.0	6.7	9.0	18	18.7
			180	2610	12.8	3.4	4.5	6.1	20.0	5.2	6.8	9.2	22.8	6.0	8.0	10.8		
			200	2900	12.7	3.4	5.0	6.7	20.0	5.2	7.6	10.1	22.6	6.0	8.9	11.9		